



Electric Pallet Stacker

LEDS 12,5 C

Load capacity 1,250kg

The best solution..... for your material handling

Design features

- Robust, stable 4-point chassis with small and compact dimensions
- Powerful AC drive motor
- Energy efficient and easy maintenance
- Excellent manoeuvrability with small turning radius

Operating elements

- Multifunctional, ergonomic handle
- Turtle mode for precise operation in small areas
- Traction switch for continuously variable forward and back driving
- Big rocker buttons for proportional lifting and lowering
- Driving with elevated handle

Standard equipment

- Modern AC technology for driving and lifting
- Vulkollan drive tyre
- Vulkollan load wheels

Options

- Battery 24V from 180 Ah to 230 Ah
- Tandem vulkollan load wheels



Manufacturers specification and design features Nov 2012

Distinguishing mark	Manufacturer's type designation			LEDS12,5C
	Drive			Electric
	Operator type			Pedestrian
	Load capacity	Q	t	1,25
	Load centre distance	C	mm	600
Weight	Load distance	X	mm	800
	Service weight, incl. Battery		kg	890
	Axle loading, laden front/rear		kg	954/1139
Tyres, Chassis	Axle loading, unladen front/rear		kg	660/230
	Tyres			Vulkollan
	Drive Wheel		mm	ø230 x 80
	Load Wheel		mm	ø85 / 78
	Support Wheel		mm	ø125 x 50
	Tread, front		mm	385
Dimensions	Tread, rear		mm	360
	Lift	h3	mm	s.table
	Height of Tiller in drive position	h14	mm	1260
	Height, lowered	h13	mm	90
	Overall length	l1	mm	1875
	Length to face of forks	l2	mm	680
	Overall width	b1	mm	660
	Fork dimensions	e / l	mm	190/1195
	Distance between fork-arms	b5	mm	550
	Groundclearance, centre of wheelbase	m2	mm	32
	Aisle width for pallets, 800x1200 mm, along	Ast	mm	2295
Performance Dates	Turning radius	Wa	mm	1500
	Travel speed, laden / unladen		km/h	5,5
	Gradeability, laden / unladen		%	7/12
Electric-Engine	Service brake			generatorisch
	AC - Drive motor		kW	1
	DC - Lift motor		kW	1,4
	Battery acc. to DIN 43535 A / B / C / no			special
	Battery voltage / nominal capacity	K5	V / Ah	24 / 250
	Battery weight		kg	250
	Impuls control for drive and lift			AC-impuls

technical modifications are subject to alteration without notice

Mast Specifications LEDES12,5C

Lifting height mm - h3	Closed height mm - h1	Capacity at height (kg)
1790	1295	1250
2090	1445	1250
2490	1645	1000
2890	1845	850
3290	2045	700

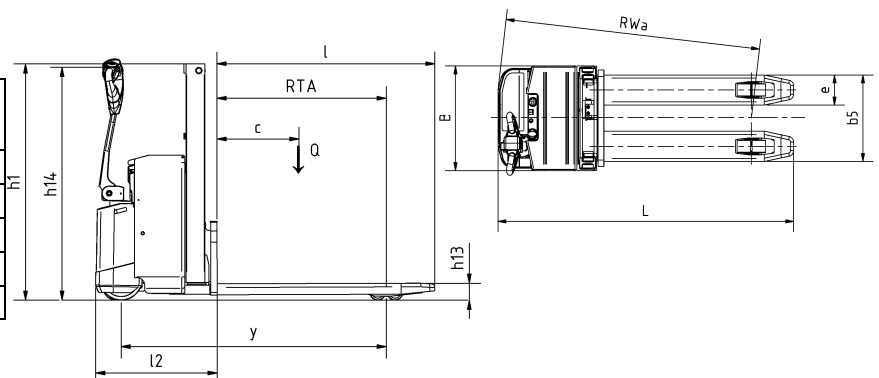

Europien Office: Europaark Noord 36A; B-9100 Sint Niklaas
Phone: +32- 3760 1643
Fax: +32- 3760 0989
Web Site: <http://www.doosaneurope.com>

